

NR ELEMENTU	NUMER CZĘŚCI	Materiał	ILOŚĆ
1	W-110-korpus	PP	1
2	W-110-daszek	PP	1

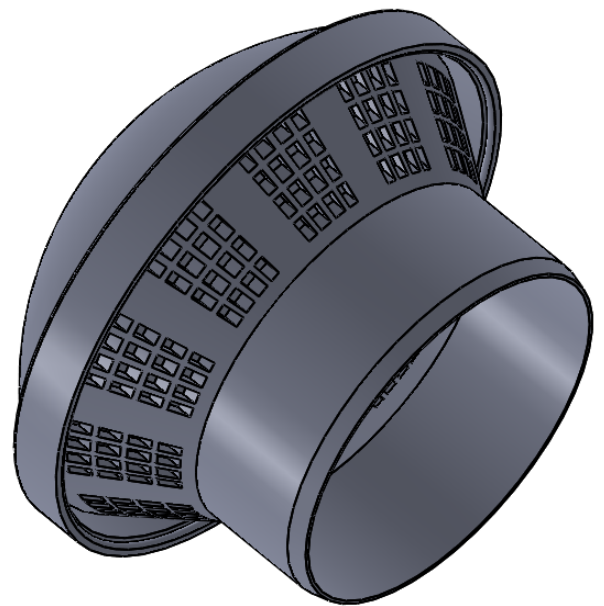
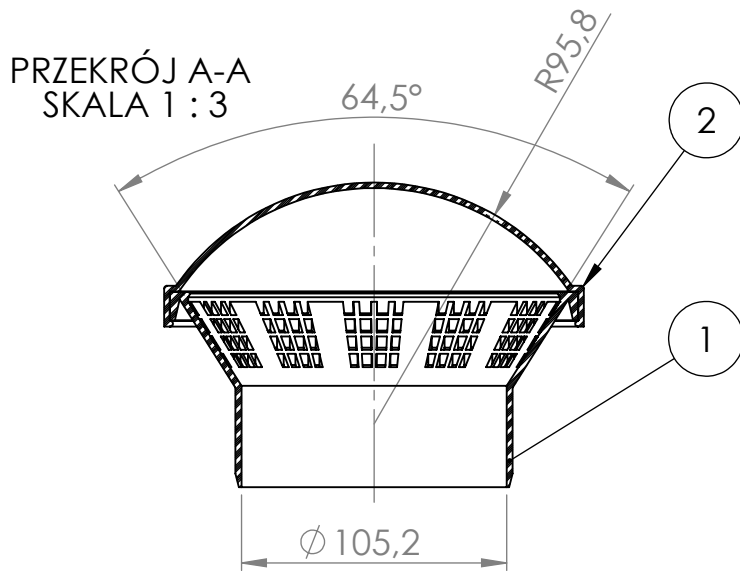
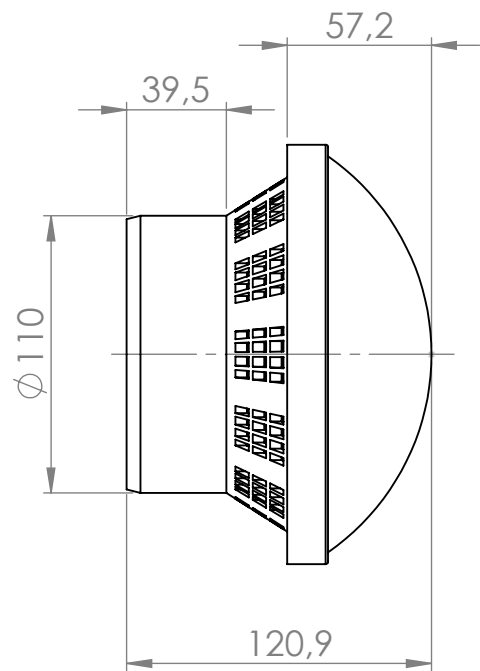
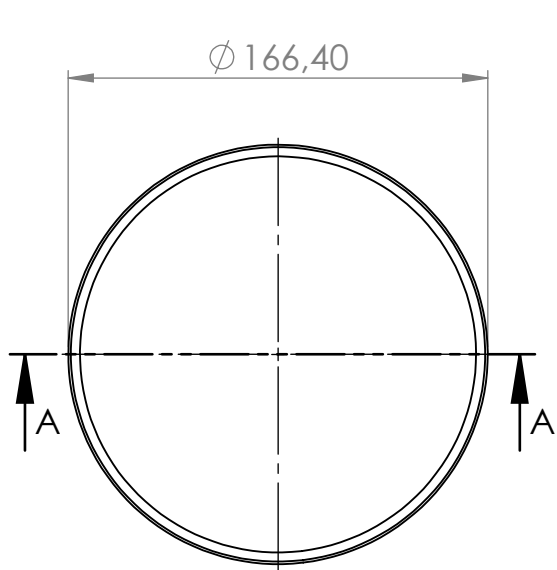

Nazwa wyrobu:

Wywiewka kanalizacyjna 110

Kod handlowy:

WP-110