

CORE C-HRV366

IMPROVING LIFE AT ITS CORE

DESCRIPTION

High performing Counterflow Heat Exchanger with maximum efficiency due to our unique and patented channel design. The C-HRV366 is characterized by the highest quality, a long life and low maintenance and can be custom made to fit your specific needs.

PRIMARY APPLICATION

Residential

PRODUCT BENEFITS

- Water washable and hygienic
- Available heights: 90 – 500 mm
- Leakage: < 1 % of nominal flow rate, 100 % leakage tested
- Material resistance: -20 °C – +60 °C

TEMPERATURE EFFICIENCY

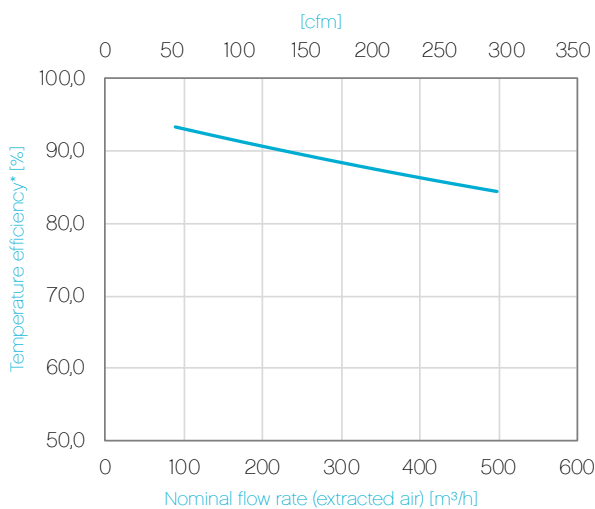

*Based on a CORE height of 500 mm, test conditions following DIN EN 3081997-06 (temp. intake air: 5°C, temp. extracted air: 25°C)

PRESSURE DROP

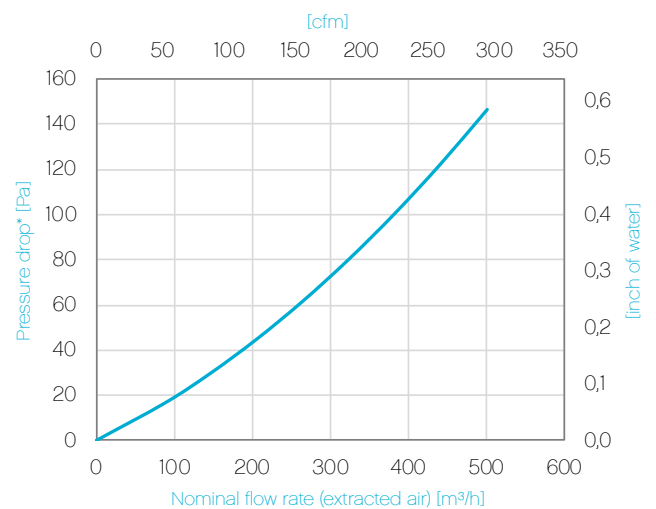

European Office:
August-Horch-Strasse 7
08141 Reinsdorf
Germany
+49 375 303 505 88
reinsdorf@core.life

North American Office:
1455 East Georgia Street,
Vancouver, BC, V5L 2A9
Canada
+ 1 604 488 1132
vancouver@core.life

www.core.life



CORE C-HRV366

TEMPERATURE EFFICIENCY (HEIGHTS 100 – 400 mm)

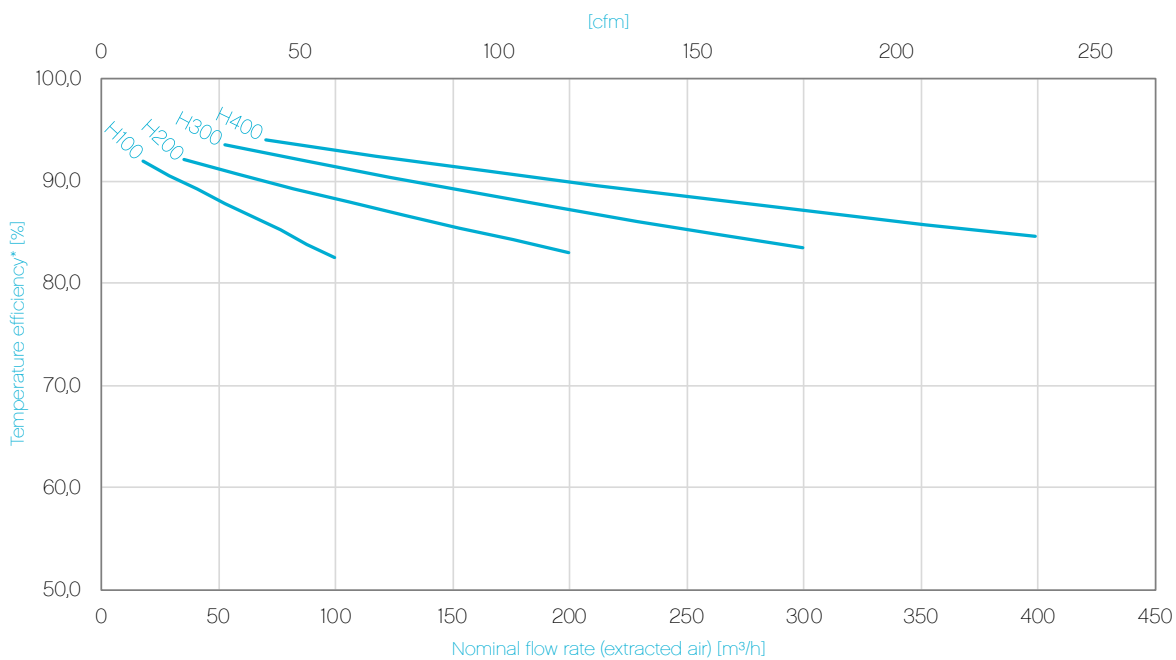

*Test conditions following DIN EN 308:1997-06 (temp. intake air: 5 °C; temp. extracted air: 25 °C)

DIMENSIONS [mm]

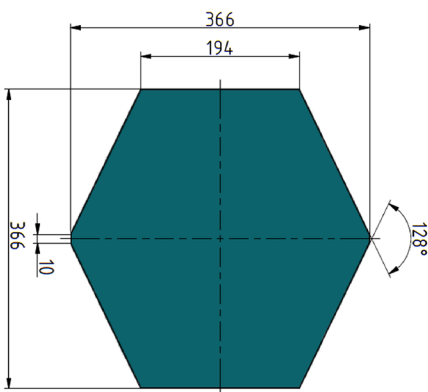

Visit us at www.core.life to learn more about us and our products. We are looking forward to your visit!

